

PATTERNS



REINING

Varsity Open INDIVIDUAL:	NRHA 11
Varsity Open TEAM:	NRHA 17
Varsity Intermediate INDIVIDUAL:	IEA 16
Varsity Intermediate TEAM:	IEA 7
Future Intermediate INDIVIDUAL:	IEA 7
Future Intermediate TEAM:	IEA 11

The following patterns are from the 2025-2026 Western Pattern Addendum and have been selected for the 2026 IEA Western National Finals Individual & Team classes. Any changes to these patterns will be posted at the show office, so please double-check during the event.

RANCH RIDING

Junior Varsity Novice INDIVIDUAL:	IEA RR1
Junior Varsity Novice TEAM:	IEA RR3
Future Novice INDIVIDUAL:	IEA RR1
Future Novice TEAM:	IEA RR3

HORSEMANSHIP

Varsity Open INDIVIDUAL:	3E
Varsity Open TEAM:	2E
Varsity Intermediate INDIVIDUAL:	2E
Varsity Intermediate TEAM:	2D
Junior Varsity Novice INDIVIDUAL:	2C
Junior Varsity Novice TEAM:	2A
Future Intermediate INDIVIDUAL:	2D
Future Intermediate TEAM:	2C
Future Novice INDIVIDUAL:	2C
Future Novice TEAM:	2A



2026 IEA Showmanship Challenge

2026 IEA/APHA Showmanship Challenge

Show Date: 06-23-2026

w w w . H o r s e S h o w P a t t e r n s . c o m

w w w . H o r s e S h o w P a t t e r n s . c o m

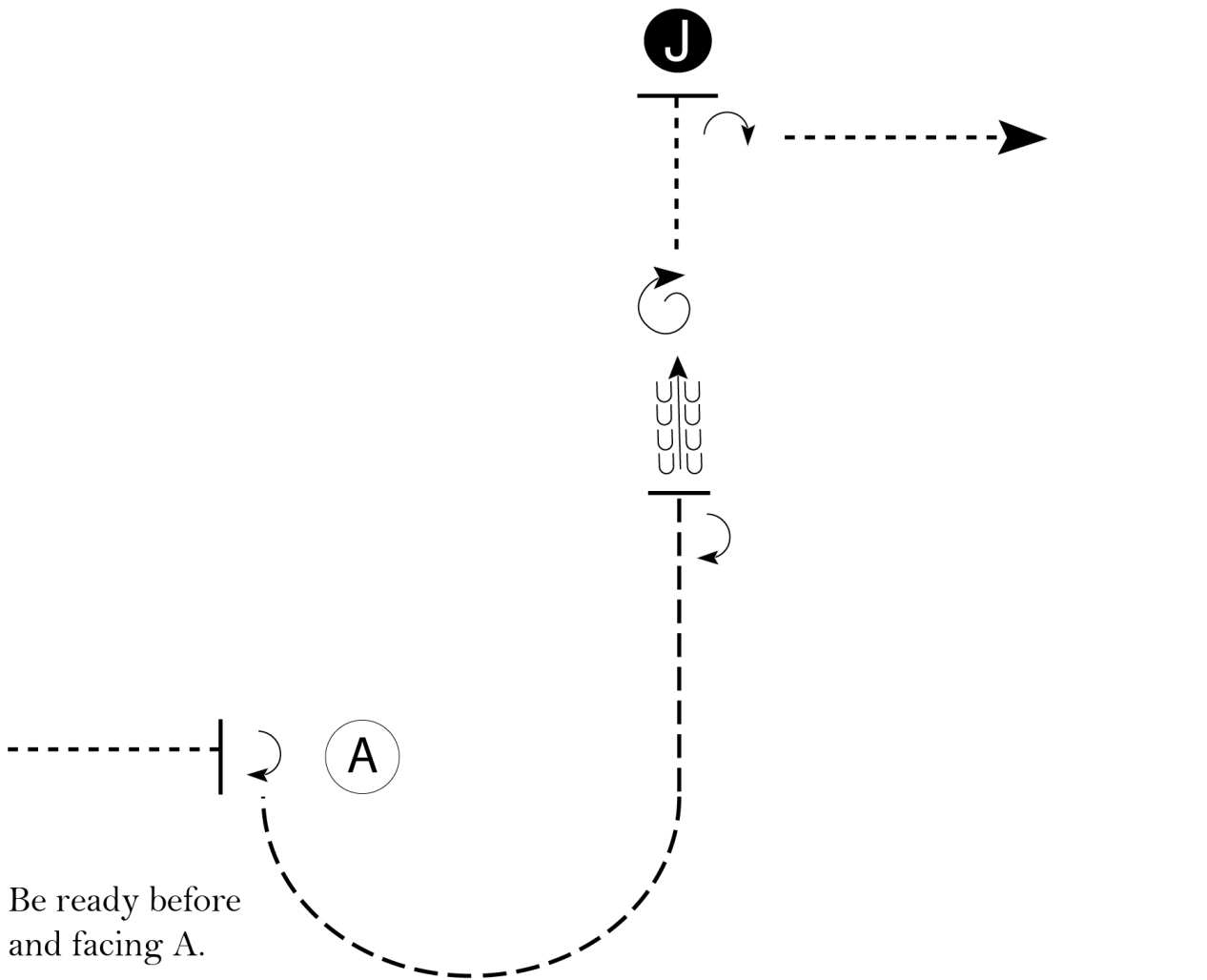

Follow the instructions of your ring steward.

[S/2-82]

Pattern Provided by:

The Judges



PATTERN 7

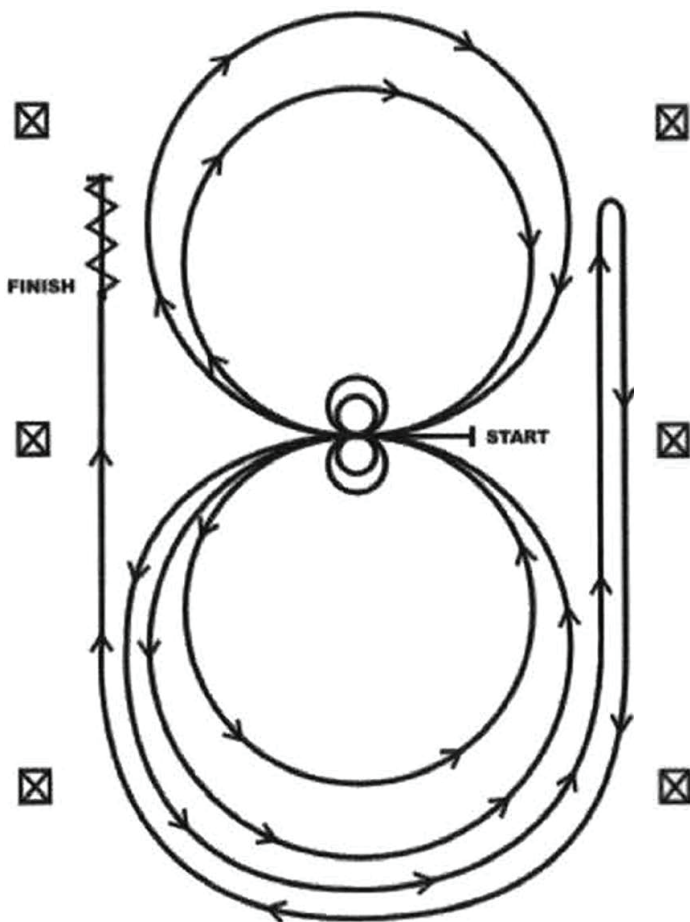

Horses may walk or jog to the center of the arena. Horses must walk or stop prior to starting pattern, beginning at the center of the arena facing the left wall or fence.

1. Beginning on the left lead, complete two circles to the left. The first circle large and fast. The second circle small and slow. Stop at the center of the arena. Hesitate.
2. Complete two spins to the left. Hesitate.
3. Beginning on the right lead complete two circles to the right. The first circle large and fast. The second circle small and slow. Stop at the center of the arena. Hesitate.
4. Complete two spins to the right. Hesitate.
5. Beginning on the left lead, go around the end of the arena, run down the right side of the arena past center marker, stop and rollback right.
6. Continue around the end of the arena to run down the left side of the arena past the center marker. Stop. Back up. Hesitate to demonstrate completion of the pattern.

Follow the instructions of your ring steward.



PATTERN 11

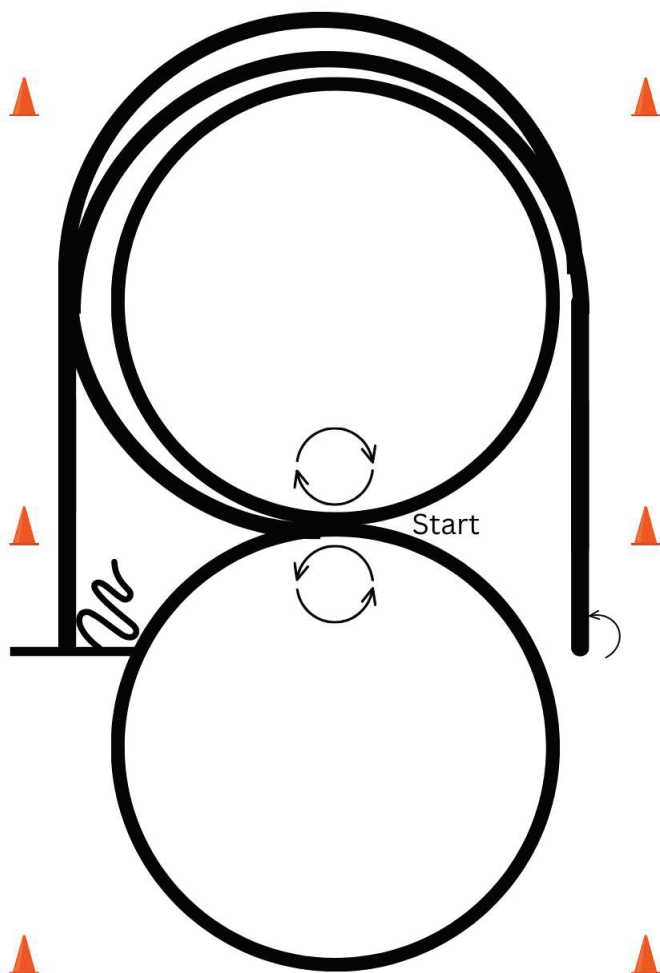

Horses may walk or jog to the center of the arena. Horses must walk or stop prior to starting pattern, beginning at the center of the arena facing the left wall or fence.

1. Beginning on the right lead, complete a circle to the right. Stop at center.
2. Complete one spin to the right. Hesitate.
3. Complete one circle to the left. Stop at center.
4. Complete one spin to the left. Hesitate.
5. Beginning on the right lead, go around the end of the arena, run down the right side of the arena past center marker, stop and do a left rollback.
6. Go around the end of the arena, run down the left side of the arena past center marker, stop and back up. Hesitate to demonstrate completion of the pattern.

Follow the instructions of your ring steward.



PATTERN 16

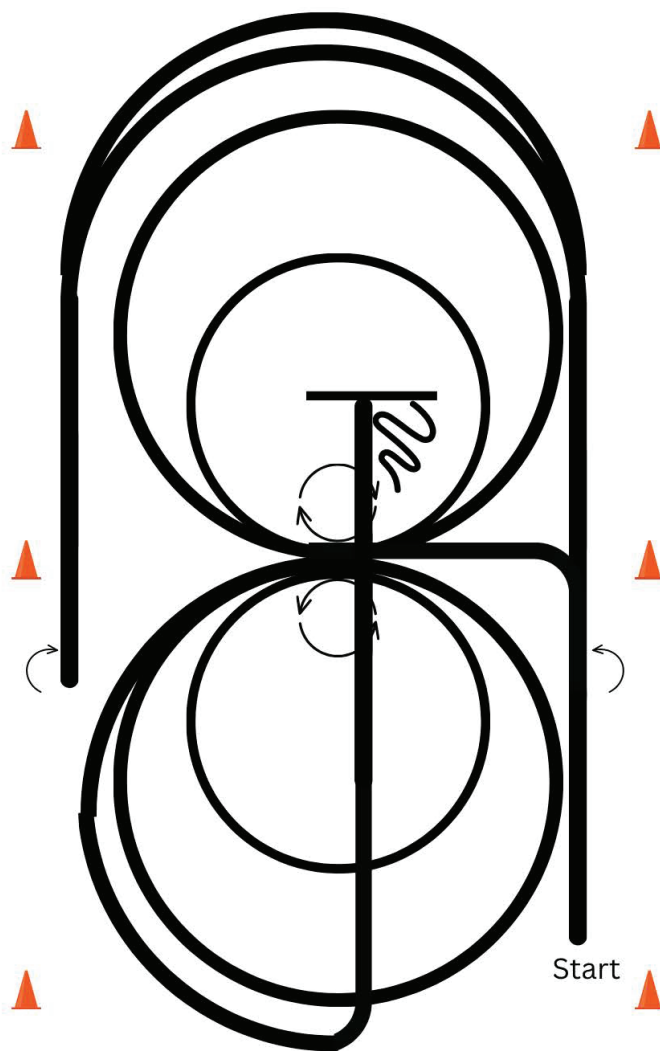

1. Beginning, lope straight up the right side of the arena, circle the top of the arena forward lope straight down the opposite or left side of the arena past the center marker. Stop and do a right rollback.

2. Continue straight up the left side of the arena, circle back around the top of the arena forward lope straight down the right side of the arena past the center marker. Stop and do a left rollback.

3. Continue up the right side of the arena to the center marker, at the center marker the horse should be on the left lead and complete two circles to the left: first large fast; second small slow. Stop at center.

4. Complete two spins to the left. Hesitate.

5. Complete two circles to the right: first large fast and second small slow. Stop at center.

6. Complete two spins to the right. Hesitate.

7. Begin a large circle to the left, do not close the circle. Continue up the center of the arena past the center marker and stop. Back. Hesitate to demonstrate completion of the pattern.

Follow the instructions of your ring steward.

Pattern 11

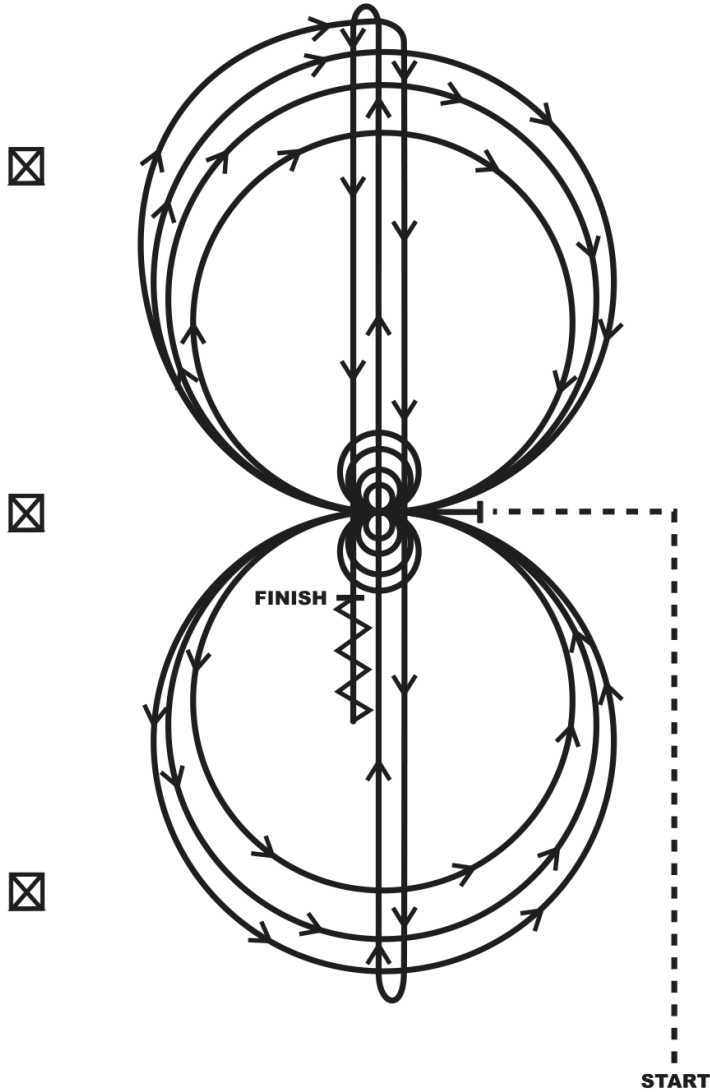

NRHA Pattern 11

Horses must jog to the center of the arena (see Judges Guide for maneuver description). Horses must walk or stop prior to starting the pattern. Beginning at the center of the arena facing the left wall or fence.

- ☒ 1. Complete four spins to the left. Hesitate.
- ☒ 2. Complete four spins to the right. Hesitate.
- ☒ 3. Beginning on the right lead complete three circles to the right; the first circle small and slow; the next two circles large and fast. Change leads at the center of the arena.
- ☒ 4. Complete three circles to the left; the first circle small and slow; the next two circles large and fast. Change leads at the center of the arena.
- ☒ 5. Begin a large circle to the right, but do not close this circle. Run down the center of the arena past the end marker and do a right rollback—no hesitation.
- ☒ 6. Run up the middle to the opposite end of the arena past the end marker and do a left rollback—no hesitation.
- ☒ 7. Run past the center marker and do a sliding stop. Back up to the center of the arena or at least ten feet (three meters). Hesitate to demonstrate completion of the pattern.



Pattern 17

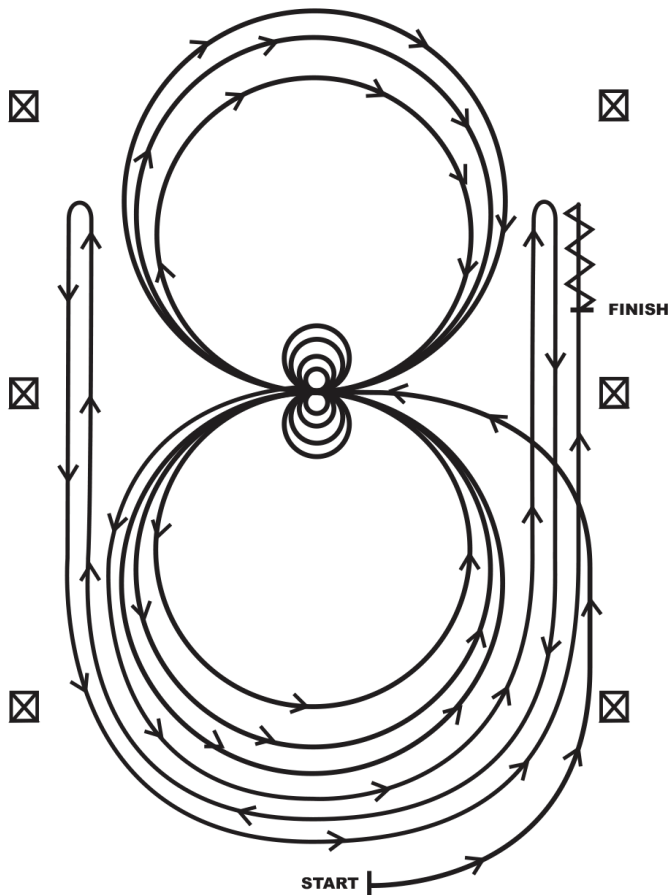

NRHA Pattern 17

Begin on the left lead. Continue to the center of the arena to begin the pattern facing toward the left wall or fence, without stopping or breaking gait.

1. Continue on the left lead, complete two circles to the left: the first circle large and fast; the second circle small and slow. Stop at the center of the arena. Hesitate.
2. Complete four spins to the left. Hesitate.
3. Beginning on the right lead, complete two circles to the right: the first being large and fast; the second circle small and slow. Stop at the center of the arena. Hesitate.
4. Complete four spins to the right. Hesitate.
5. Beginning on the left lead, run a large fast circle to the left, change leads at the center of the arena, run a large fast circle to the right, and change leads at the center of the arena (figure 8).
6. Continue around previous circle to the left but do not close this circle. Run up the right side of the arena past the center marker and do a right rollback at least 20 feet (6meters) from the wall or fence-no hesitation.
7. Continue around previous circle but do not close this circle. Run up the left side of the arena past the center marker and do a left rollback at least 20 feet (6 meters) from the wall or fence-no hesitation.
8. Continue back around previous circle but do not close this circle. Run up the right side of the arena past the center marker and do a sliding stop at least 20 feet (6 meters) from the wall or fence. Back up at least 10 feet (3 meters). Hesitate to demonstrate completion of pattern.

